

### Tire Pressure Monitoring System (TPMS) Sensor

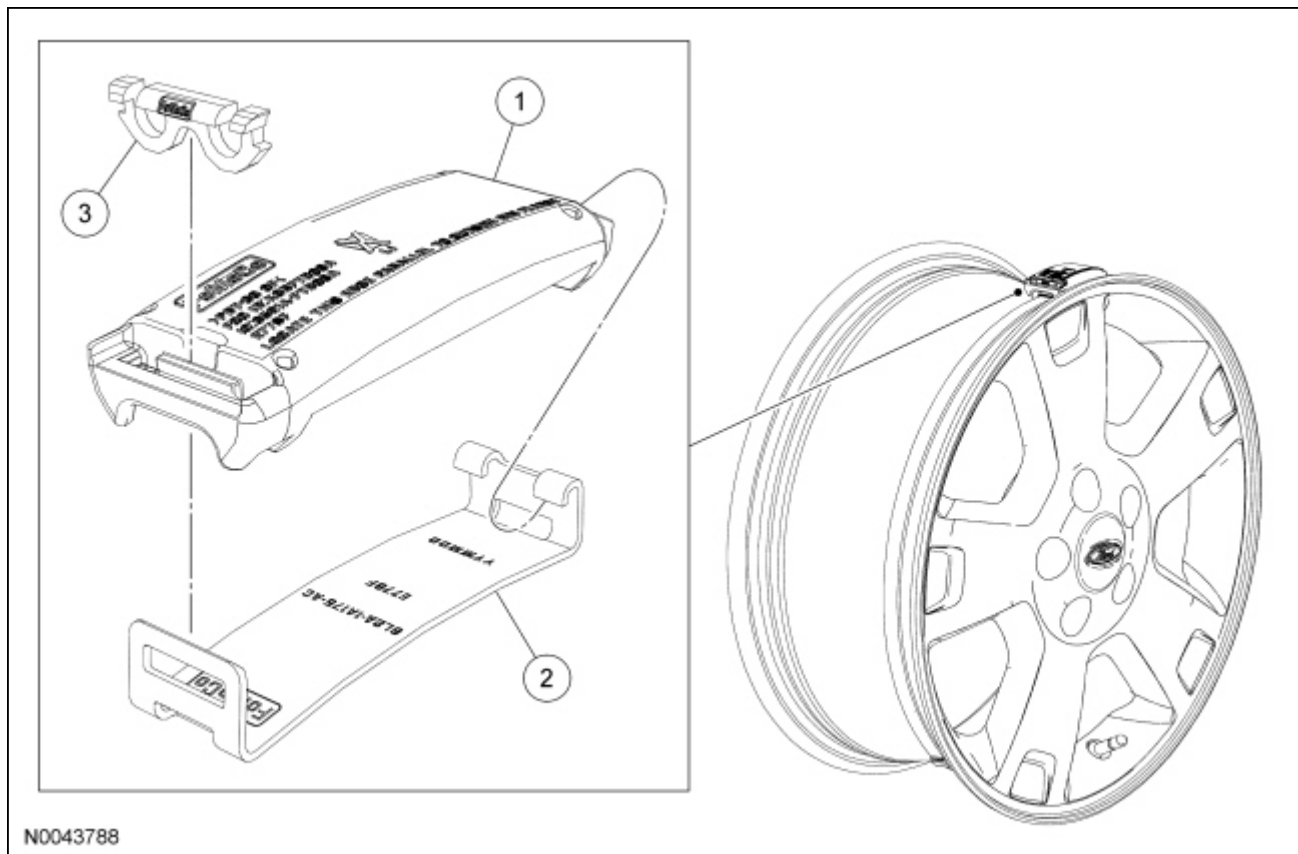

N0043788

| Item | Part Number | Description                       |
|------|-------------|-----------------------------------|
| 1    | 1A150/1A189 | Tire pressure sensor/sensor kit   |
| 2    | 1A175       | Sensor cradle                     |
| 3    | 14C202      | Locking clip (also part of 1A189) |

#### Disassembly

**⚠ WARNING:** The tire pressure monitoring system (TPMS) sensor battery may release hazardous chemicals if exposed to extreme mechanical damage. If these chemicals contact the skin or eyes, flush immediately with water for a minimum of 15 minutes and get prompt medical attention. If any part of the battery is swallowed, contact a physician immediately. When disposing of TPMS sensors, follow the correct procedures for hazardous material disposal. Failure to follow these instructions may result in serious personal injury.

**NOTE:** Tire pressure sensors are equipped with Lithium-ion batteries and must be disposed of accordingly.

**NOTE:** Tire pressure sensors are manufactured in multiple colors based on their application. When installing a new sensor, make sure the color of the sensor being installed matches the color of the sensor that was removed. The different colored sensors are **not** interchangeable.

**NOTE:** The sensor can be removed and installed without removing the strap or the cradle.

1. **NOTICE:** The sensor, cradle and strap may be damaged by incorrect tire mounting or dismounting. Dismount the tire only as instructed.

Remove the tire from the wheel. For additional information, refer to [Wheel and Tire](#) in this section.

2. **NOTICE:** Do not use a large screwdriver. Apply minimum force during removal or damage to the sensor locking clip may occur.

Using a pocket screwdriver or similar tool, remove the sensor locking clip.  An animated version of this procedure is available on-line.

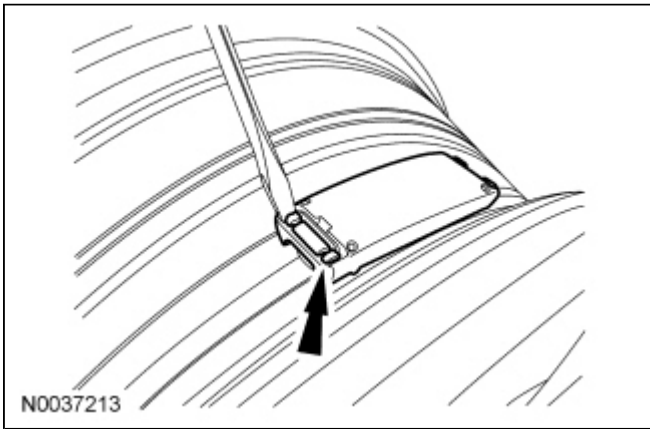

3. **NOTICE:** Do not use a large screwdriver. Apply minimum force during removal or damage to the sensor may occur.

Using a pocket screwdriver or similar tool, detach the sensor from the cradle.  An animated version of this procedure is available on-line.

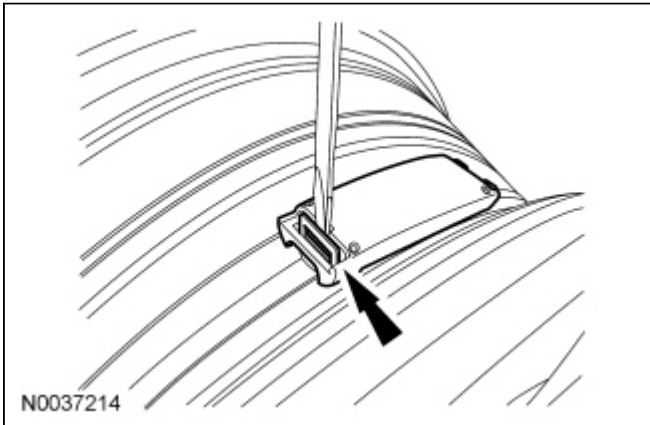

4. Remove the sensor.

## Assembly

1. **NOTICE:** Damage to the sensor may occur if excessive force is applied during sensor installation.

**NOTE:** Make sure the sensor is fully seated into the cradle. The sensor will make a "click" noise when correctly seated.

Position the sensor into the cradle by inserting the hinge end of the sensor into the hook end of the cradle and pushing the opposite end of the sensor down onto the cradle.

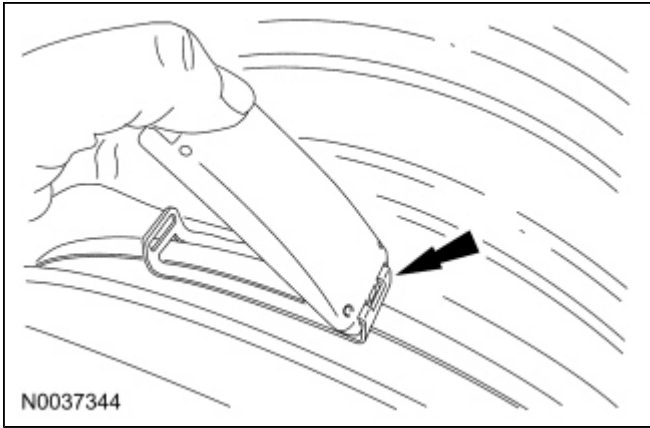

- NOTE:** The locking clip can only be fully seated when installed in the correct orientation. If the sensor locking clip cannot be fully inserted, then the sensor may not be fully seated on the cradle or the locking clip may be inserted backward.

Insert a new locking clip into the sensor.

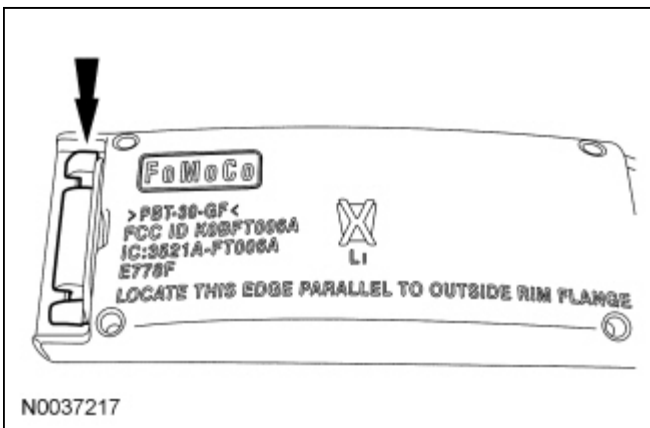

- NOTICE:** The sensor, cradle and strap may be damaged by incorrect tire mounting or dismounting. Mount the tire only as instructed.

Install the tire onto the wheel. For additional information, refer to [Wheel and Tire](#) in this section.

- NOTE:** A new tire pressure sensor is shipped in an off mode (or battery saver mode) and must be turned on before it can be trained. To turn the sensor on, install it on a wheel, mount the tire and inflate the tire to the recommended inflation pressure. Wait at least 2 minutes, then continue with the sensor training procedure.

Train the tire pressure sensor(s). For additional information, refer to [Tire Pressure Monitoring System \(TPMS\) Sensor Training](#) in this section.

---

